



UK Registered Design No. 6059841



## KEY FEATURES

- Durable polyethylene one-piece construction gives excellent strength
- Solid grey laminate insert helps ensure the top is level, ideal for outdoor use
- Wheelchair accessible design
- Floor fixed option to deter mishandling
- Anti-tamper locking mechanisms
- Strength and durability tested for severe contract use, (inc. 500kg static load test)

 → Core colour



## MATERIAL/FABRICATION

Rotationally moulded, durable polyethylene, one-piece construction provides excellent strength and stability. Flamed, textured finish further strengthens the fire-retardant, water-resistant, UV-stabilised shell. Anti-microbial material gives high chemical resistance (e.g. ammonia, sodium hydroxide) throughout the product.

The unique corkscrew design creates a very strong connection between the table top and base, secured with anti-tamper fixings. A solid-grade laminate table top provides a durable, water-resistant surface making the table suitable for indoor and outdoor use. The table is available in 2 options - a heavily weighted option (118kg) which deter lifting, and a floor fixed option which for added safety makes the table totally immovable.

## TEST STANDARDS

- Strength and Durability (EN 15372:2016 Test level 3)
- Fire retardant to BS 5852:2006 ignition source 5
- UV resistance tested to UV 21+ stating it can withstand 21,000 sunlight hours
- Compliant with flammability standards UL94 HB
- EN 15372:2007 Test level 2 with an additional 500kg Static Load Test

## OPTIONS

- Unable to mix and match top and base, comes as 1 colour as standard
- Heavily weighted to 118kg non-floor fixable option available (1RYPT-120)

## ASSEMBLY

Arrives assembled and ready to use

## COLOR/FINISH

Moonwalk Grey (*stock colour*)

Other colours from our Ryno® palette Granite, Cool Green, Icon Purple, Epic Blue, Lime Green, Vegas Yellow, Thunder Grey, Dusty Blue, Dusty Pink, Teal, Violet Purple and Warm Terracotta (*special colours - MOQs and increased prices apply*)

## DELIVERY

Stocked colour lead time 5 weeks (*special colours - MOQs and increased leadtimes apply*)

## INSTALLATION/FITTING

Please advise if floor fixing is required when ordering as fixed items are made differently. All products must be fitted carefully following Pineapple's product instructions (where available). If not, any guarantee is at risk of becoming null and void

## MAINTENANCE

Our multi-purpose Ryno cleaning wipes are available to help keep your Ryno products looking their best. Avoid using abrasive materials or cleaning agents, solvents, steam cleaning or jet washing. Use bleach and chlorine disinfectant with caution and avoid placing in close proximity to sources of heat. Read more here <https://uk.pineapplecontracts.com/upholstery/care-guidance/>

## WARRANTY

Lifetime guarantee against all manufacturing faults

## DISCLAIMER

Extreme temperature changes (e.g. a cold night followed by a warm sunny day) may cause air inside the product to expand, causing short-term changes to its shape.

Due to the nature of the rotational moulding process, flat surfaces on Ryno® products may feature slight undulations which do not detract from the product's strength or durability.

# RYNO<sup>®</sup> PEDESTAL TABLE

1RYPT  
760H | 1050Dia. (mm)  
Weight: 30kg or 118kg  
Seating capacity: 4

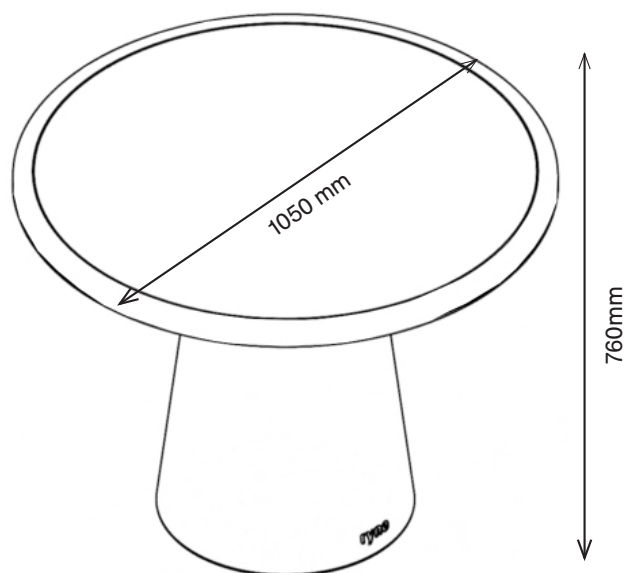

T  
E  
W

+44 (0)1622 237830  
sales@pineapplecontracts.com  
uk.pineapplecontracts.com

# Pineapple