

# MAGNA PLUS CHAIR

1MG1-900

790H | 944W | 790D (mm)

Seat Height: 447mm

Weight: 55kg



## KEY FEATURES

- Plywood reinforcement for added strength
- 'Zero-depth' seams prevent concealment
- Fully enclosed base to prevent concealment
- Fixed seat and back cushions to prevent misuse
- Strength and stability tested for severe contract use

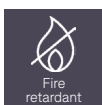

### MATERIAL/FABRICATION

Carcass made from a mix of particle board and plywood with plinth base on our Plus range, which prevents dust and dirt gathering underneath. Strong plywood reinforcement offers excellent levels of durability and strength. All cushions fixed to the base to ensure that they are not taken off with anti-stash seams option to prevent hiding of contraband. Cushioned areas made from fire retardant, CMHR (combustion modified high resilience) foam is safe for both users and staff.

### TEST STANDARDS

- Fire retardant to BS7176:2007 source 5
- Strength and stability tested to EN 1957:2012
- Strength and stability tested to BS EN 15373: 2007 (Test Level 3 - severe use), BS 4875: Part 1 : 2007 - Test Level 5 and BS EN 1022: 2005.
- Seat has been strength and stability tested to 80,000 cycles as per EN 12520:2010

### OPTIONS

- Available in armchair, 2-Seater and 3-Seater options
- Available in Standard or Plus levels or reinforcement

### COLOUR/FINISH

Plinth base available in Natural Rockford Hickory.

### FABRIC

Available in a wide choice of fabrics including Vinyl, Waterproof, Non Waterproof and Leather

### ASSEMBLY

Arrives assembled and ready to use

### DELIVERY

Lead time 8 weeks

### INSTALLATION/FITTING

No fitting required

### MAINTENANCE

See upholstered furniture section of our care guidelines <https://uk.pineapplecontracts.com/upholstery/care-guidance/>

### WARRANTY

7 year guarantee (does not include fabrics)

T  
E  
W

+44 (0)1622 237830

sales@pineapplecontracts.com

uk.pineapplecontracts.com

# Pineapple

# MAGNA PLUS CHAIR

1MG1-900

790H | 944W | 790D (mm)

Seat Height: 447mm

Weight: 55kg

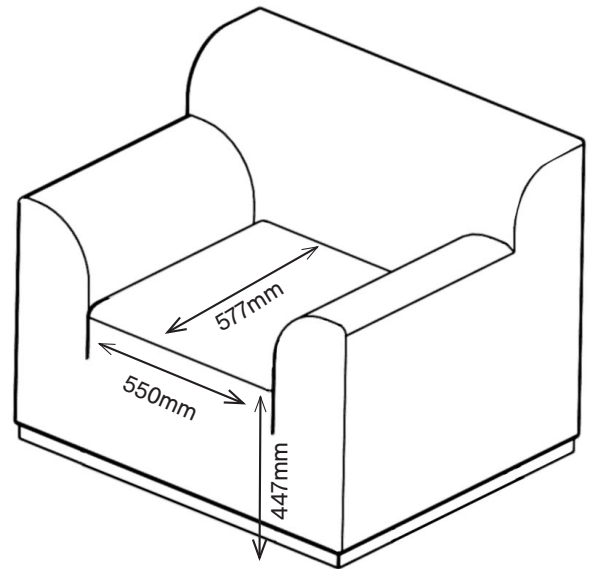
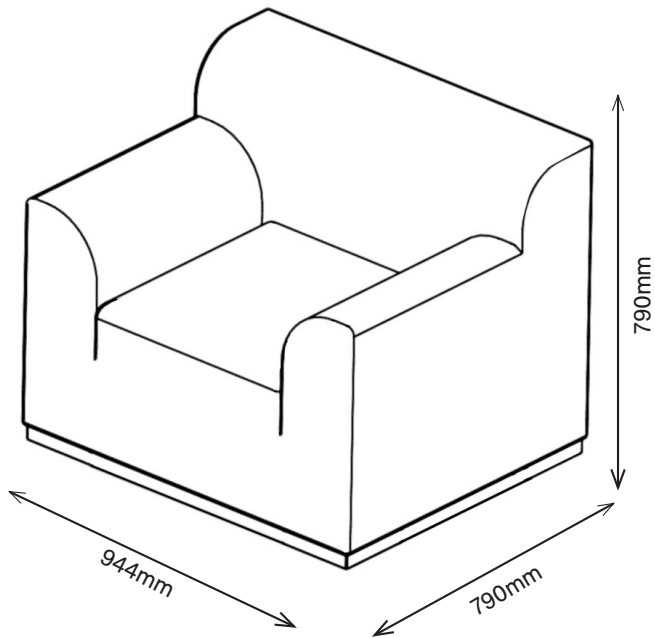

T  
E  
W

+44 (0)1622 237830

[sales@pineapplecontracts.com](mailto:sales@pineapplecontracts.com)

[uk.pineapplecontracts.com](http://uk.pineapplecontracts.com)

Pineapple