

# RYNO<sup>®</sup> COMBO TABLE → FLOOR FIXING



*These instructions apply only when fixing to a concrete floor with no obstructions (e.g. under floor heating, cables, plumbing, etc.). When fixing to any other surface, or with obstructions, please contact your Pineapple representative for further advice*

## REQUIRED ITEMS

- 3 x floor brackets with studs  
*(only provided with floor fixed version)*
- 3 x hold down plates  
*(only provided with floor fixed version)*
- 6 x M10 nuts/washers  
*(only provided with floor fixed version)*
- 2 x M10 security bolts  
*(only provided with floor fixed version)*
- 6 x concrete hardware fixings
- 8 x M10 security bolts for tabletop
- 1 x masonry drill bit
- Handheld power drill
- 1 x T45 security drill bit



+44 (0)1622 237830

sales@pineapplecontracts.com

# Pineapple

# RYNO<sup>®</sup> COMBO TABLE → FLOOR FIXING

01

Place the floor fixing brackets in position ensuring they interlock correctly.  
Mark floor using holes in floor fixing brackets and install appropriate floor fixing hardware into floor

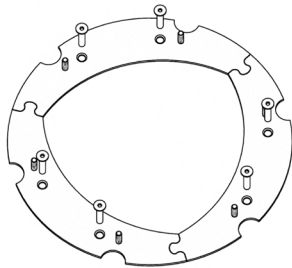
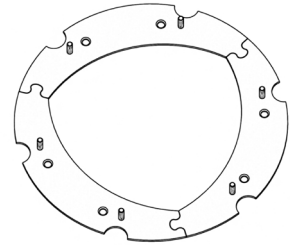

Fix brackets into floor using suitable hardware

02

03

Place the base of Ryno combo table over the floor fixing brackets ensuring the studs pass through. Ensure the base is firmly in contact with the floor

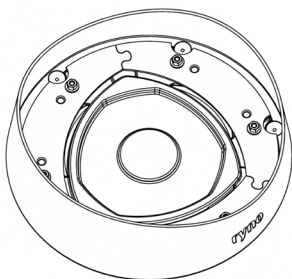
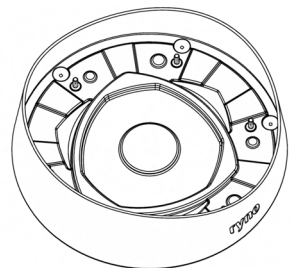

Place the remaining three hold down plates over the studs ensuring they are in the correct orientation and attach to the brackets using the six nuts and washers provided

04



+44 (0)1622 237830



sales@pineapplecontracts.com

**Pineapple**

# RYNO<sup>®</sup> COMBO TABLE → FLOOR FIXING

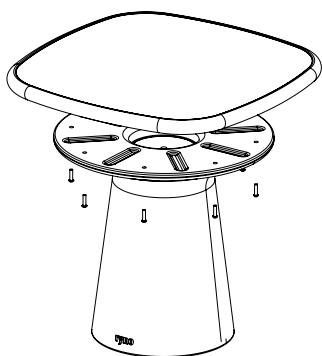

Bolt tabletop to base using the 8x M10 bolts

05

06

Table with top fully assembled

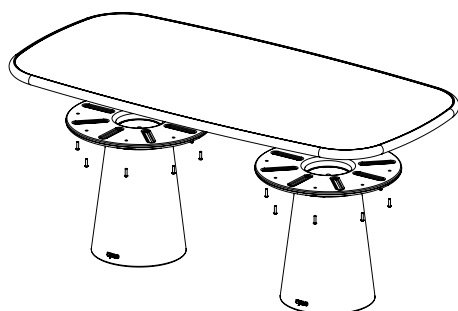
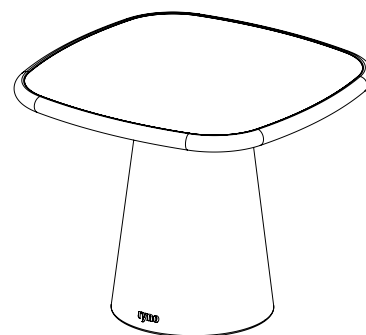

**Please note:** If assembling a double pedestal you follow the same fixing method as above.

07

T  
E

+44 (0)1622 237830

sales@pineapplecontracts.com

**Pineapple**

# RYNO<sup>®</sup> COMBO TABLE → FLOOR FIXING

## DISCLAIMER

- Ensure the proper and adequate hardware is used to secure furniture
- Ensure fixings are appropriate for the anchoring material
- Use fixings of an appropriate strength and consider using security fixings in challenging environments
- Consider using high strength thread-locker on fixings in challenging environments
- Ensure all gaps are sealed with the appropriate anti-pick mastic after product installation if necessary
- Please read all instructions carefully to ensure proper installation. Failure to read and follow instructions may result in inadequate product installation and void of warranty
- Pineapple shall not be held liable for any consequences caused by the improper installation of products to the installer or the end user



+44 (0)1622 237830

[sales@pineapplecontracts.com](mailto:sales@pineapplecontracts.com)

**Pineapple**