

KEY FEATURES

- Heavily weighted to 142kg to deter misuse
- Wheelchair accessible design
- Hygienic wipe-clean material
- Material compliant with flammability standards UL94 HB & BS 5852:2006
- Durable polyethylene one-piece construction provides excellent strength
- Base is 100% recyclable



MATERIAL/FABRICATION

The base is a rotationally moulded, durable polyethylene, one-piece construction provides excellent strength and stability. Flamed, textured finish further strengthens the fire-retardant, water-resistant, UV-stabilised shell.

Tabletop available in Natural Rockford Hickory with an anti-spill PU Grey edge. Available as a weighted option (142kg) which deter lifting, the base is also floor fixable with a secure hidden floor fixing solution.

Tabletop Edge: Mid-Grey 028 PU Edging
Laminate options: Natural Rockford Hickory or Grey

OPTIONS

- Anti-tamper floor fixed option - **1RYCT-F-00**
- Optionally made with 40% reused content
- 960 x 960 (mm) tabletop also available
- Also available as a double pedestal table 2400 x 1200 (mm) option with an increased seating capacity of 8 (see below)



TEST STANDARDS

- Fire retardant to CAL 133 and UL 94 HB
- Fire retardant to BS 5852:2006 ignition source 5

COLOUR/FINISH

CORE COLOURS



Moonwalk Grey



Cool Green



Sand



Dusty Blue



Warm Terracotta



Hickory



Granite



Dusty Pink



Thunder Grey



Violet Purple



Grey



Teal



Icon Purple



Epic Blue

NON-CORE COLOURS

LAMINATE TOP OPTIONS

DELIVERY

[core colours] leadtime 5 weeks | [non-core colours] will have longer leadtimes and additional costs

ASSEMBLY

Arrives assembled and ready to use

INSTALLATION/FITTING

Additional weighting can be carried out prior to delivery. Please advise if floor fixing is required when ordering as fixed items are made differently. All products must be fitted carefully following Pineapple's product instructions (where available). If not, any guarantee is at risk of becoming null and void

MAINTENANCE

Avoid using abrasive materials or cleaning agents, solvents, steam cleaning or jet washing. Use bleach and chlorine disinfectant with caution and avoid placing in close proximity to sources of heat. Read more here <https://uk.pineapplecontracts.com/upholstery/care-guidance/>

WARRANTY

Lifetime guarantee against all manufacturing faults

DISCLAIMER

Extreme temperature changes (e.g. a cold night followed by a warm sunny day) may cause air inside the product to expand, causing short-term changes to its shape.

Due to the nature of the rotational moulding process, flat surfaces on Ryno® products may feature slight undulations which do not detract from the product's strength or durability.

Floor fixable options cannot be additionally weighted as the necessity to floor fix for immovability negates any need for internal weight to be added.

1RYCT
800H | 960W | 960D (mm)
Weight: TBA
Seating capacity: 2-4

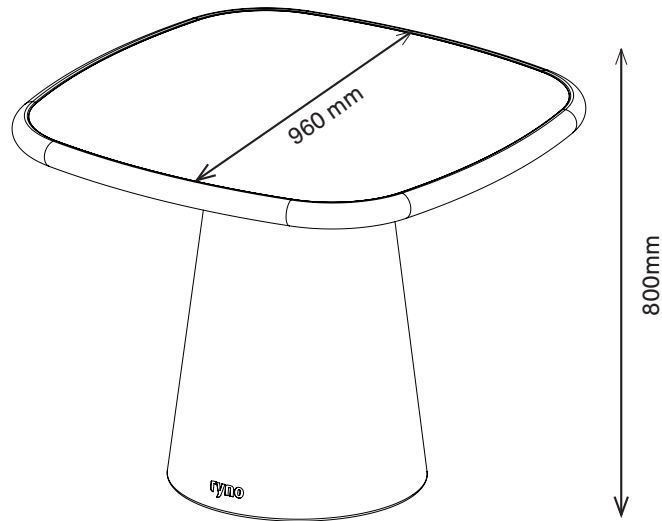

1RYCT-142
800H | 1200W | 1200D (mm)
Weight: 142kg
Seating capacity: 4

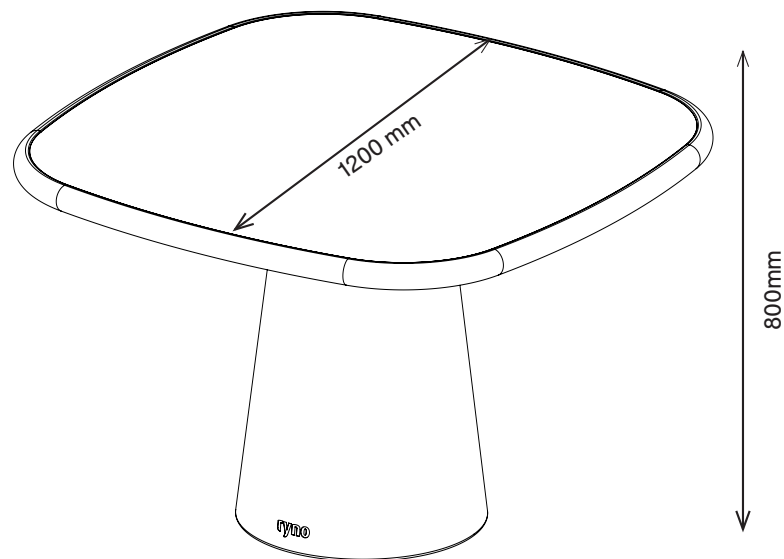

RYNO[®] COMBO TABLE

1RYCT
800H | 2400W | 1200D (mm)
Weight: TBA
Seating capacity: 8

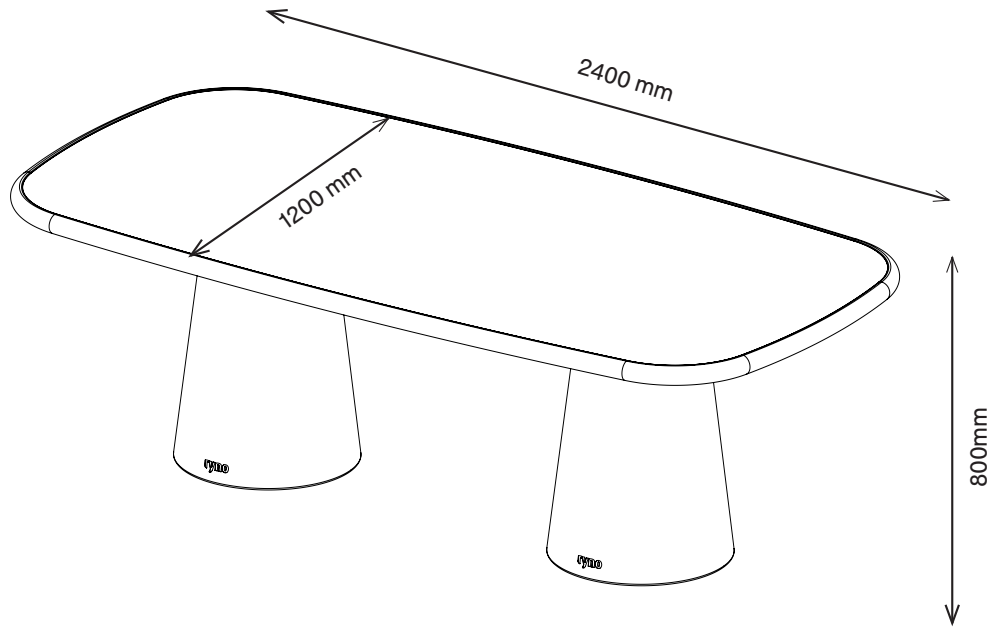

T
E
W

+44 (0)1622 237830
sales@pineapplecontracts.com
uk.pineapplecontracts.com

Pineapple